

Original Research Article

Optimizing Daylight Integration through Light Pipes in Dhaka's Office Buildings: A Simulation and Field Study Approach

ABSTRACT

The rapid urbanization of Dhaka has resulted in the proliferation of middle and high-rise office buildings, often designed with deep plans and large open layouts to maximize economic and spatial efficiency. However, these designs typically rely heavily on artificial lighting, with core areas devoid of natural daylight, contributing significantly to energy consumption—up to 50% of total building energy use. While daylight has well-documented physiological and psychological benefits, its effective integration into deep office spaces remains a challenge.

This study explores the integration of light pipes with HVAC systems, forming a dual ducting system to enhance daylight utilization in office buildings. Light pipes are innovative devices that transport and distribute daylight while minimizing heat transfer, providing an effective solution for illuminating deep, windowless areas. Using EnergyPlus software for simulation analysis along with field study, the research examines the optimal design parameters for light pipe installation, including length, width, number, and positioning. Findings reveal significant potential for daylight inclusion through light pipes, improving energy efficiency and workspace quality. The study synthesizes insights from literature, field observations, and simulations to propose design guidelines for consultants. These strategies aim to optimize the luminous environment of Dhaka's office buildings, fostering sustainable, cost-effective, and occupant-friendly working environments.

Keywords: Daylighting, light pipes, experiment, simulation, office buildings

1.0 INTRODUCTION

With rapid development, commercial and economic activities increase parallel which accommodate lots of office spaces and buildings in Dhaka city. Deep plans are a common practice in middle and high-rise office building design and large open plans have become the preferred office layout by modern businesses due to the flexibility of the space and economic benefits achieved from maximum plot to gross floor area ratios (Ahmed et al., 2011). Environmentally conscious assessments of building design recognize that daylight (along with natural fresh air) is an important commodity and should be exploited to the full. Generally, people, when asked, always prefer to work in a daylit environment. There is a growing acknowledgement that daylight produces positive effects, both physiological and psychological (Sawyer, 2022; Knoop et al., 2020). Consequently, the deep core areas of these buildings are difficult to naturally illuminate by side windows and depend entirely on electricity for illumination. Often major spaces of office buildings are running with artificial lighting. Recent studies suggest artificial lighting accounts for close to 50% of the total energy used in a building, through daylight is readily able to replace much of this energy use (Wong, 2017). Daylight is a major influence on building design. The light pipes are innovative devices able to transport and distribute daylight without heat transfer in dark rooms (Canziani et al., 2004). Innovative daylighting strategies seek to break the conventional strategies barriers and 'guide' daylight beyond their limits to the remote zones and windowless spaces, whether in new or existing buildings. Daylight Guidance System (DGS) uses light pipes to distribute daylight, which occupy significant amounts of space (Paul, 2019). Most of the office buildings are also running with artificial heating, cooling and ventilation systems

which already occupy a lot of ceiling space in the buildings. The integration of light ducts with heating, ventilation and air conditioning (HVAC) ducts (dual ducting system) could be a practical solution that may ensure quality working environment, energy saving, reduction of costs and space management (Paul, 2019). The aim of this research is to study the installation of light pipes for office buildings to increase the use of daylight in working space in the context of Dhaka. To explore the possibilities of installing light pipe, computer simulation analysis was used by Energy Plus software (Crawley et al. 2001). Further simulation analysis was done to refine the design parameter, e.g. length and width, number and position of light pipe for the most effective use of daylight. Literature review, field observations, model experiments and simulation studies together provide the basis of design guidelines for consultants to design appropriate luminous environments. It is expected that the design strategies and recommendations from this research will improve the luminous environment of deep spaces of office buildings in Dhaka by installing light pipes system. This study discusses methodology to describe the basic information required to identify on which the simulation could be conducted. This study contains the details of the surveyed offices for the selection of that specific space which will be simulated. Experimental studies with scale models have been done to understand daylight inclusion patterns by side windows, roof openings and light pipes. The findings from field monitoring and results of the experiments were used in the simulation study which has been described in this study.

2.0 FIELD SURVEY

Dhaka, as the capital city of Bangladesh, serves as a hub for numerous government organizations, non-governmental organizations (NGOs), multinational corporations and private companies, many of which have established their corporate or head offices in the city (Joarder, 2007). To explore the physical characteristics of these office spaces, a field survey was conducted encompassing ten offices situated across different locations in Dhaka. These

offices were selected to represent a diverse range of settings. The survey was designed to gather comprehensive data through a structured questionnaire about specific aspects of the physical environment within these offices. While the survey aimed to provide a foundation for subsequent daylight simulation studies, its scope was deliberately limited to exclude factors such as building surroundings, orientation and interior materials and finishes. These parameters were standardized in the simulation study to maintain focus on other variables such as spatial configuration. Key items assessed during the survey included the total number of stories in each building and the specific floors surveyed, the dimensions (length and width) of office spaces, the area illuminated by daylight versus artificial light, and details about the height of openings (including type, sill and lintel heights). Additionally, the survey examined the height of various interior elements such as work planes, partitions and ceilings as well as health symptoms reported by employees working in these offices. The offices surveyed varied significantly in their characteristics. For example, Opsonin Chemical Industries Ltd., located on New Eskaton Road, is a nine-story building where the fifth floor was surveyed. Akiz House's Cement Division, situated on Gulshan Link Road, Tejgaon, consists of fourteen stories, with data collected from the fourth floor. Similarly, Pubali Bank Ltd. in Motijheel and Markentile Bank Ltd. in Dilkusha are larger buildings with fifteen and twenty-two stories respectively and their seventh and twelfth floors were included in the study. Other notable offices in the survey included Renata Ltd. in Mirpur, Bangladesh Bank's head office in Motijheel, and BASF Bangladesh Ltd. in Gulshan. Additional offices surveyed included the I-Pay Office at Silver Tower in Gulshan, IFIC Bank Ltd. at Progoti Saroni and Robi's Head Office at Nafi Tower on Gulshan Avenue. The selected offices represented a wide range of building types, functions and architectural designs, providing a robust dataset for analyzing daylight utilization and its potential implications for employee wellbeing and energy efficiency. This focused study offers valuable insights that will inform design

recommendations for enhancing daylight performance in office environments. Detail layout plan and other information are given below (Table 1):

Table 1. Field survey information

Office Name (A)	No. of Story	Survey Floor Location	Core Location	Opening	Length	Width	Floor Area
Opsonin Chemical Industries Ltd.	09	5th	West	North, East, South	28.65 m	25 m	693 sqm
Akiz House	14	4th	West	North, East, South	43 m	18 m	621 sqm
Pubali Bank Ltd. Credit Division	15	7th	North/ South	North, East, West	35 m	16.15 m	590 sqm
Markentile Bank Ltd.	22	12th	Centre/ East, West	North, South	38 m	15.24 m	663 sqm
Renata Ltd.	03	1st	West/ East	North, South	19.2 m	16 m	285 sqm
Bangladesh Bank, Head Office	31	24th	West/ East	North, South	45.72 m	28 m	1400 sqm
BASF Bangladesh Ltd.	11	7th	Middle	North, East, South, West	46.25 m	19.80 m	945 sqm
“I-Pay”	19	13th	East	West, North, South	40 m x 18.29 m		725 sqm
IFIC Bank Ltd., ProgotiSaroni Branch	15	1st	West	East, North, South	48.76 m	17 m	818 sqm
Robi Head Office, Nafi Tower	20	5th	South	East, North, West	29 m	20m	539 sqm

3.0 OBSERVATIONS FROM FIELD SURVEY

As Dhaka city possesses almost similar climatic, geographical, technical and other aspects in its different parts, the characteristics features are also quite similar for office in different areas. Some variations in features were, however, identified during the survey.

Building Floor Number and Surveyed Floor: After selection it was found that different height offices were surveyed. There was one building which was three (03) storied and on the opposite side, the highest no. of story of surveyed building was 31. At the same timesurveyed floor situated in different intermediate floors of these buildings. At two (02) cases, it was 1st floor but most of the cases, it was 5th floor and above. These findings are presented in Fig.1.

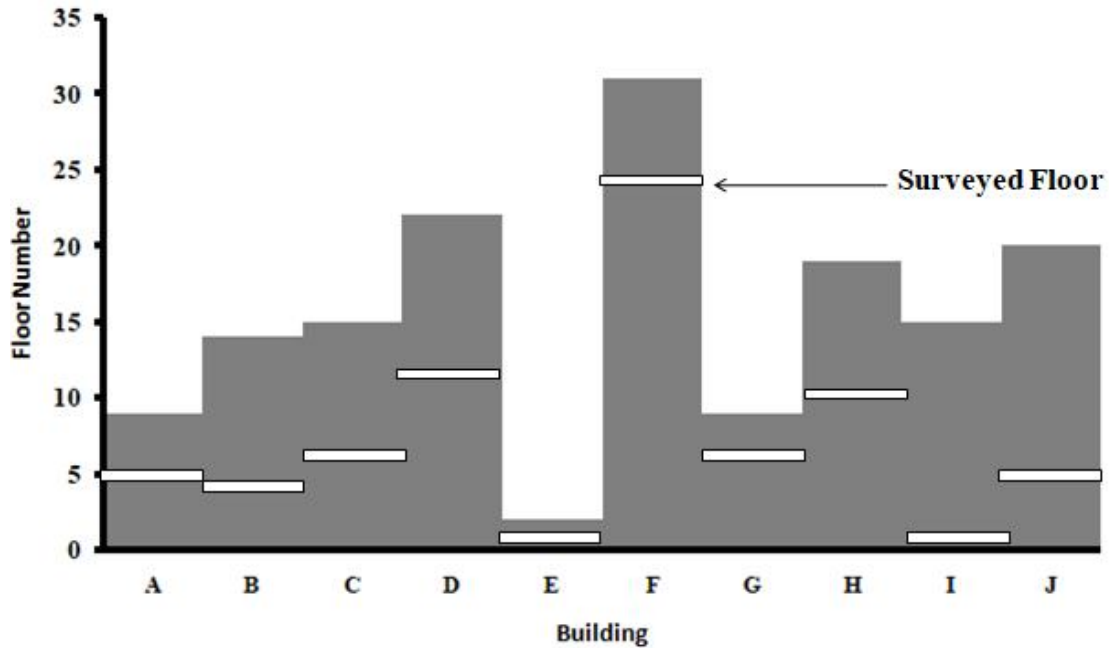

Figure 1. Floor number and surveyed floor

Ceiling, sill and work plane height with relation to floor height: In the surveyed cases the floor height of the buildings varies from 3m to 3.66m. Among them most of the floors (6 cases) have a height of 3.66 m. The lintel height varies from 2.1m to 2.75m but in most cases it was 2.1m. Most of the offices were covered by curtain glass. So, the skill level of most cases was 0m but there were 2.1m walls in four cases. So, for those buildings, the seal level was 2.1m. That's why the height of the opening varies from 1.35m to 2.75m. The average opening height was 2.4m. But there was uniformity in work plane height. In all cases, it was 0.75m. These findings are presented in Fig.2.

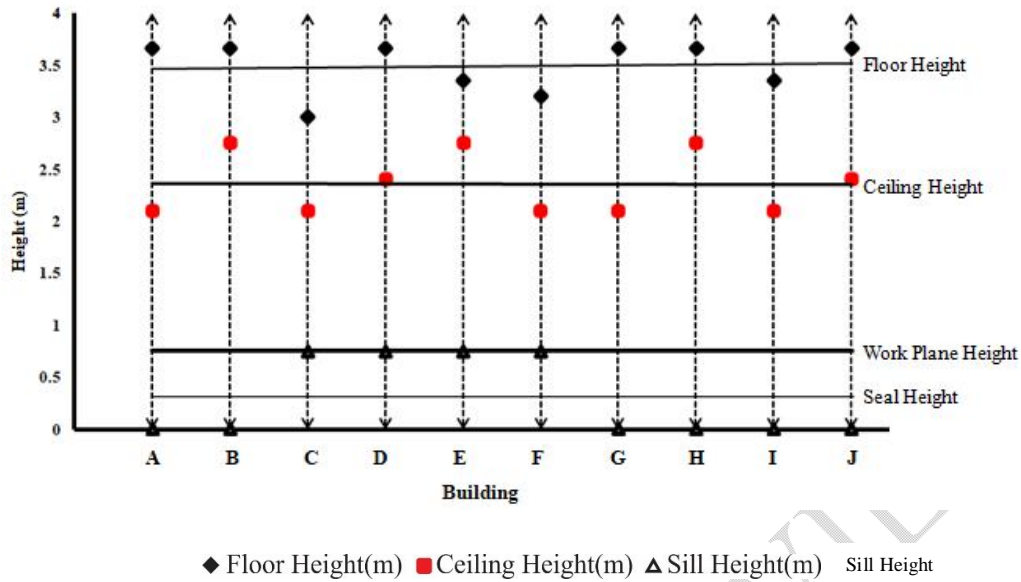

Figure 2. Ceiling, sill and work plane height with relation to floor height

Partition height and work plane height: In the surveyed office spaces 90% of the offices use low partitions to demarcate individual workstations. Most of the offices (7 cases) have 1.2m high partitions around workstations. The partition height was less than 1.2m (1.06m) in two (02) cases. But previously it was found that the work plane height was 0.75m in all cases. So, these partitions become a barrier for using daylight (weather available). Only one office did not use any partition. These findings are presented in Fig.3.

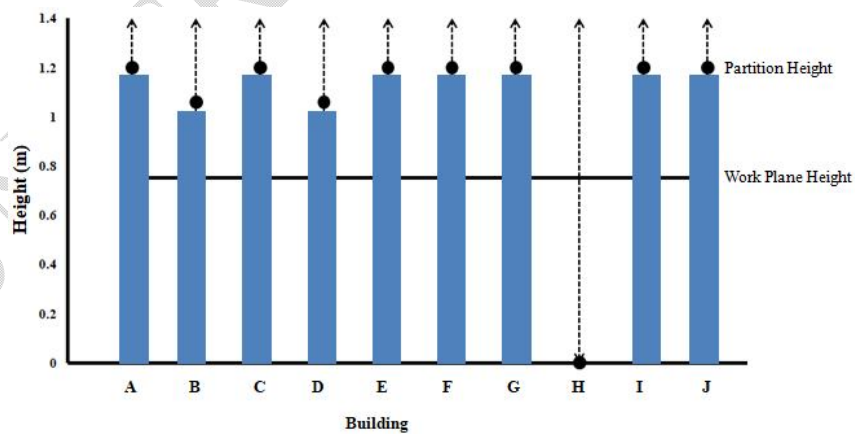

Figure 3. Partition height with relation to work plane height

Illumination Level: Illumination levels were measured at the open office areas of the ten offices. As the targeted area was far away from openings, the employees must use artificial

light. In all case illumination levels were measured with the artificial lights switched on and when the artificial lights were off, to test the daylight penetration and its contribution to the illumination of the space during the day. In the absence of task lighting, only ambient lighting data could be obtained. Fig.4 shows that the illumination level was very poor without artificial light as the open area of office spaces with low partition generally situated at the center of the office where there was no scope of inclusion of daylight. But when the employee uses artificial light, in the cases, the illumination level was up to the standard (Bangladesh National Building Code, BNBC) task lighting level (300-450 lux). However, there were also some examples which did not reach the standard of illumination even with artificial lights switched on.

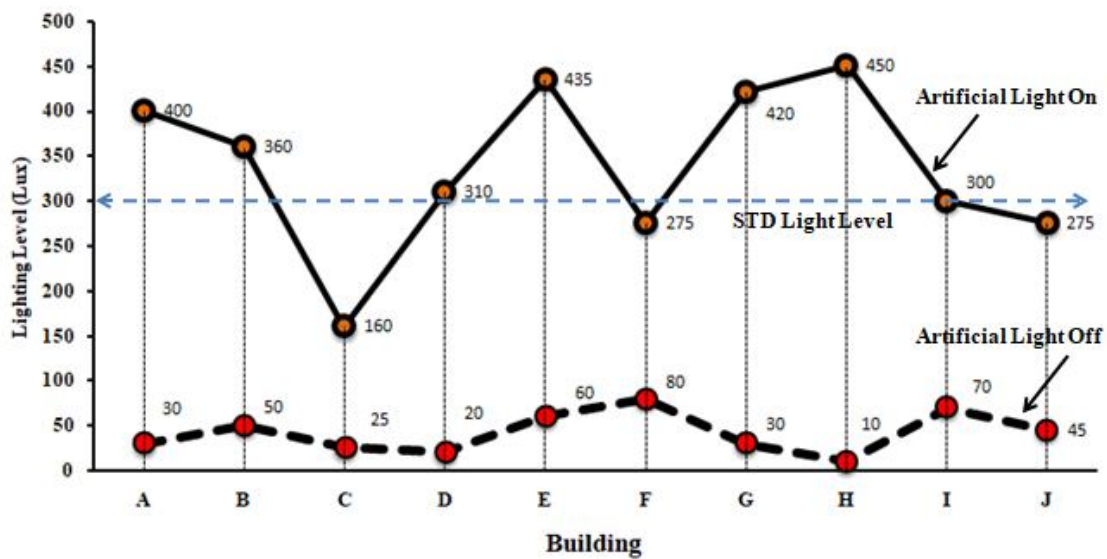

Figure 4. Illumination level comparison

Building's Floor Width: The length and width of the office building is a major factor because it determines the area where penetrated daylight reaches. As it was found that average ceiling height was 2.4m, so daylight can reach max 4.8m on an average (2 times of opening height). In the surveyed cases, half of the minimum width was 7.62m. So, the surveyed spaces were far away from the range of reaching daylight by side opening (Fig.5).

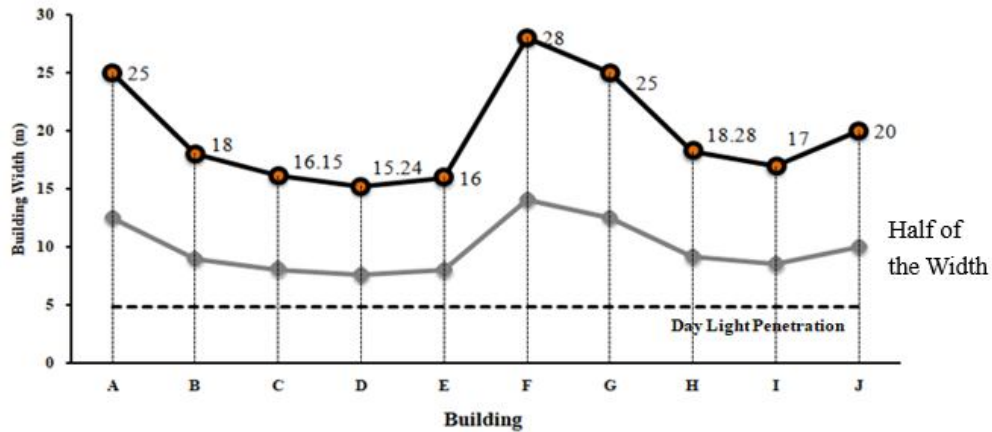

Figure 5. Comparison of different surveyed building's floor width

Health Symptoms: By the questionnaire survey about the physical characteristics of the office spaces, 220 employees gave their feedback about their health issues which were affected by the lighting condition of the workspace. It was found that 95% of people had the opportunity to work in natural daylight, 48% of them have no problem with health issues. But 11% of them suffered from headache, 18% had eye irritation and 23% were suffering from fatigue (Fig. 6).

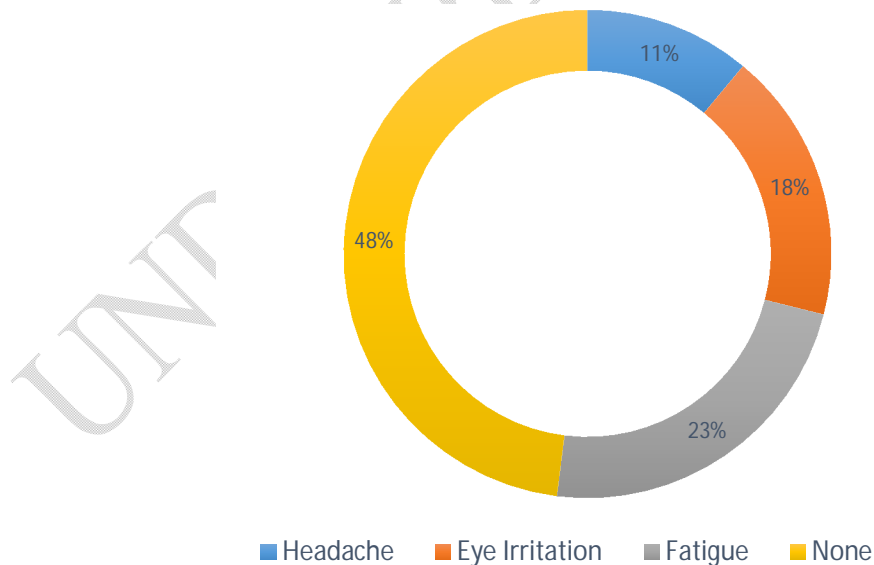

Figure 6. Health Symptoms of the employees who work beside openings

On the other hand, of the 125th no. of employees who worked in the open office area, only 13% of them had no health issue. But 25% of them suffered from headache, 26% had eye irritation and 26% were suffering from fatigue (Fig. 7).

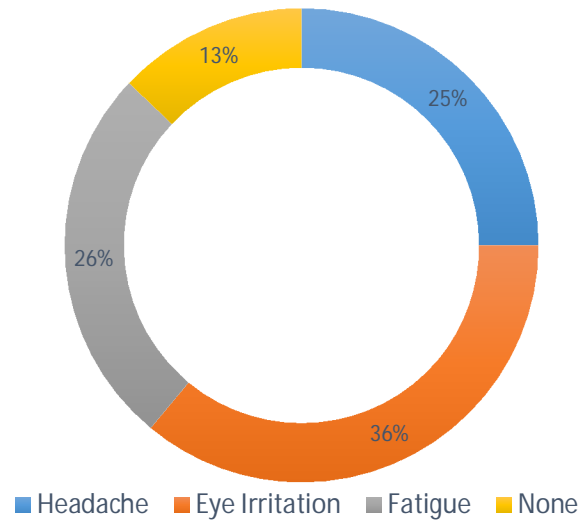

Figure 7. Health Symptoms of the employees who work without daylight

The field survey of office spaces in Dhaka revealed critical observations that underline the challenges and opportunities associated with daylight access in these environments, particularly emphasizing the potential of integrating light pipes. A significant portion of office spaces, approximately 25% to 40%, were found to be entirely devoid of direct daylight, while an additional 15% to 20% were only partially exposed to it. These poorly lit areas were typically located at the center of the floor plan, far removed from exterior windows and natural light sources.

The architectural configurations of the surveyed buildings also played a crucial role in daylight availability. The height of floors, ceilings, and window openings (measured from lintel to sill) were found to directly influence the inclusion of daylight. However, even in offices equipped with full-height windows, natural light failed to penetrate deeply into the interior spaces. This was further compounded by the widespread use of false ceilings, which effectively limited the positioning of windows on walls, confining daylight access to low-

level windows. This design choice restricted the depth of daylight penetration, leaving large portions of the interiors inadequately lit.

Illumination levels measured during the survey indicated that lighting conditions in these office spaces often fell well below both national and international standards. Near windows, natural light dominated as the primary source of illumination. However, as one moved further into the interior spaces, a sharp decline in illumination levels was observed, with artificial lighting proving insufficient to compensate for the lack of natural light. This disparity resulted in areas where daylight had little to no influence, exacerbated by the absence of adequate openings or the distance from light sources.

The impact of these lighting conditions extended beyond illumination deficiencies. Employees working in poorly lit, deep interior spaces frequently reported various health issues, including headaches, eye irritation and fatigue. In contrast, employees positioned closer to windows, where natural light was more prevalent, reported fewer such issues. These findings underscore the adverse health implications of prolonged work under artificial lighting without access to daylight.

The survey's insights highlight the urgent need for innovative solutions, such as the integration of light pipes, to address the challenges of daylight access in office buildings. Light pipes, with their potential to channel natural light into deep interior spaces, could significantly enhance both illumination levels and the overall wellbeing of office occupants. These observations serve as a foundation for further studies and interventions aimed at creating healthier, more energy-efficient office environments.

4.0 SELECTION OF CASE BUILDING FOR SIMULATION

The main target of the entire investigation was to identify one office as an example space for computer simulation. This case office would match the target goal of the research (inclusion of daylight in deep space) along with common typology of office in Dhaka city.

The criteria for site and building selection to determine the case office space were based on the following factors (Joarder et.al, 2009).

- i. The site should be in urban context and should have characteristics typical of the general urban fabric of the Dhaka city.
- ii. The case office building should represent the trend of typical office design in Dhaka.
- iii. The case office building should be architect-designed and built in accordance with the Building Construction Regulations of the City Authority.
- iv. The case office space should have minimum complexity in design and detailing for easy of simulation with different daylight strategic options.
- v. Internal layout of the case office space should be such that, there should be provision for daylight inclusion near opening along with deep spaces where direct sunlight can't reach by opening.
- vi. The scale and volume of the building be convenient to handle within the time limit of this study.

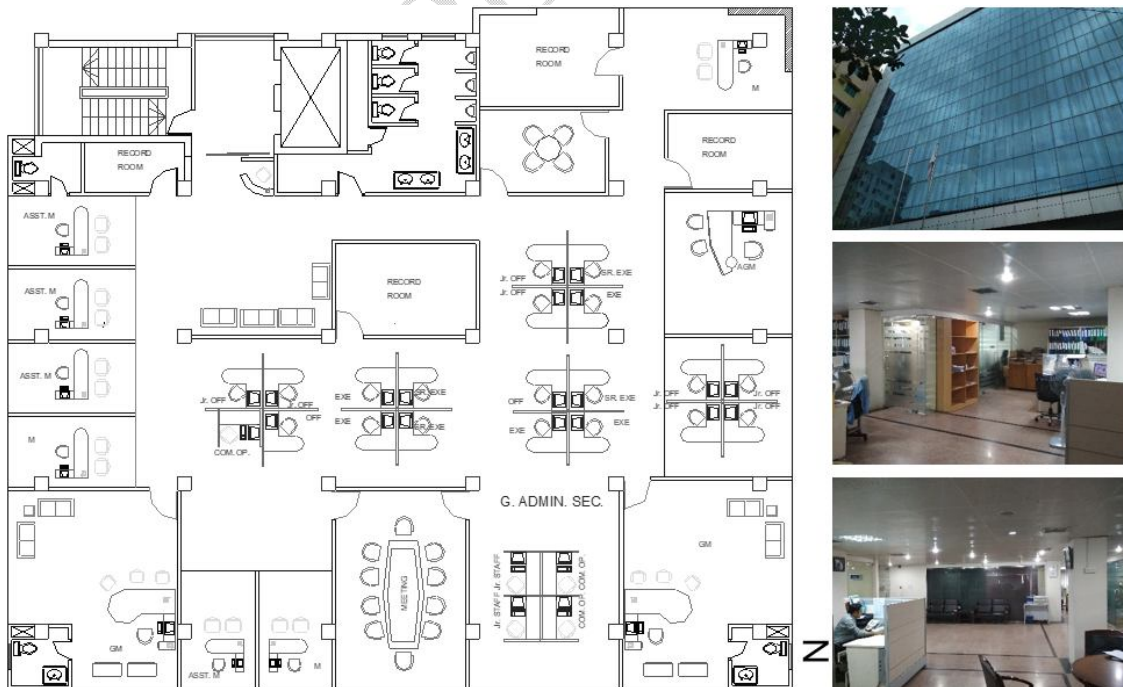

Figure 8. Field survey data of Opsonin Chemical Industries Ltd.

According to the above criteria the nine storied Opsonin Building (Corporate office of Opsonin Chemical Industries Ltd.) was selected for detailed examination and simulation study. The 5th floor of the building was chosen as example space to take for detail experiment. This floor is one of the typical floors, the plan of which is repeated in other floors. The building has a 7m wide road on the west, some single storied semi-pacca establishments on the east, another nine storied building 2.5 m from the northern edge and 2.5 m from the south is a three storied building. There is a four storied building and some greenery just opposite the road in front of the office building (Fig. 9)

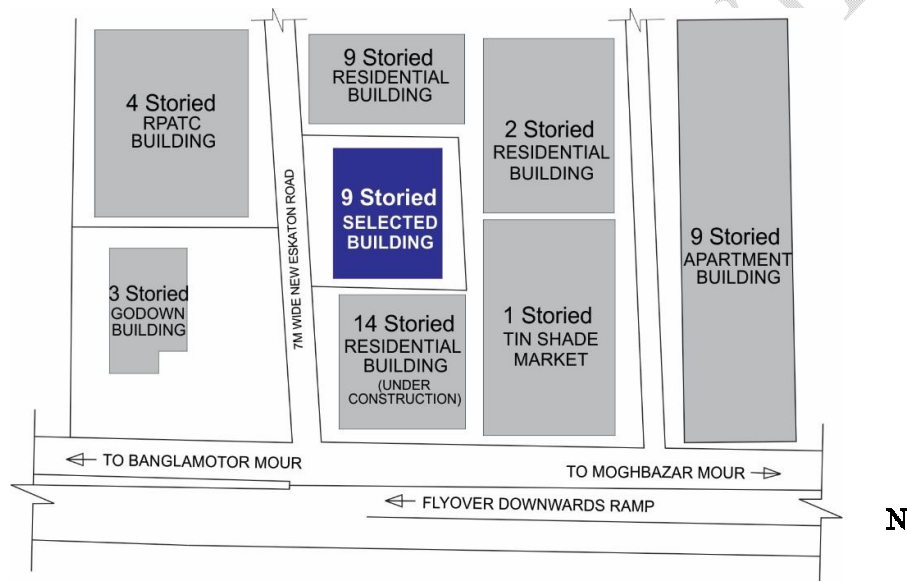

Figure 9. Location Map (with site and surroundings)

After selection of the building a check has been done (Table 2) to see that the example building in fact suitable for detail observation and simulation (Sailor, 2008).

Table 2. Different aspects for case building

Characteristics	Opsonin Building
Type	High Rise Intermediate Floor Designed as Office Building 3 Side open
Date of Establishment	2001-2007
Starting Time	9.00 AM
Closing Time	6.00 PM

Window Type	Sliding (3 Sides) and Fixed(Front)
Window Material	Glass
Type of the Glass	Coloured
Glass Specification	Thickness: 10mm, Conductivity: 0.9 W/m-K, Visible Transmittance: 0.55, Solar Transmittance: 0.775. Density: 160 lb/ft ³
Floor Height	3.0m
Window Height	2.1m
Sill Height	Below 0.75m
Lintel Height	2.1m
External Shading	No external shading
Internal Blinds	Vertical
Ceiling Height	2.1m
Partition Height	1.2 m
Work Plane Height	0.75 m

The fifth floor of the nine storied corporate office of Opsonin Chemical Industries Limited was taken as an Example Space. Currently this 5th floor is being used as a meeting and general office space for the office employee. Another reason to choose this floor for analysis was that this floor has a large open office area in the middle portion of the floor, i.e. uninterrupted by too many internal partitions and workstations (Fig. 10-12).

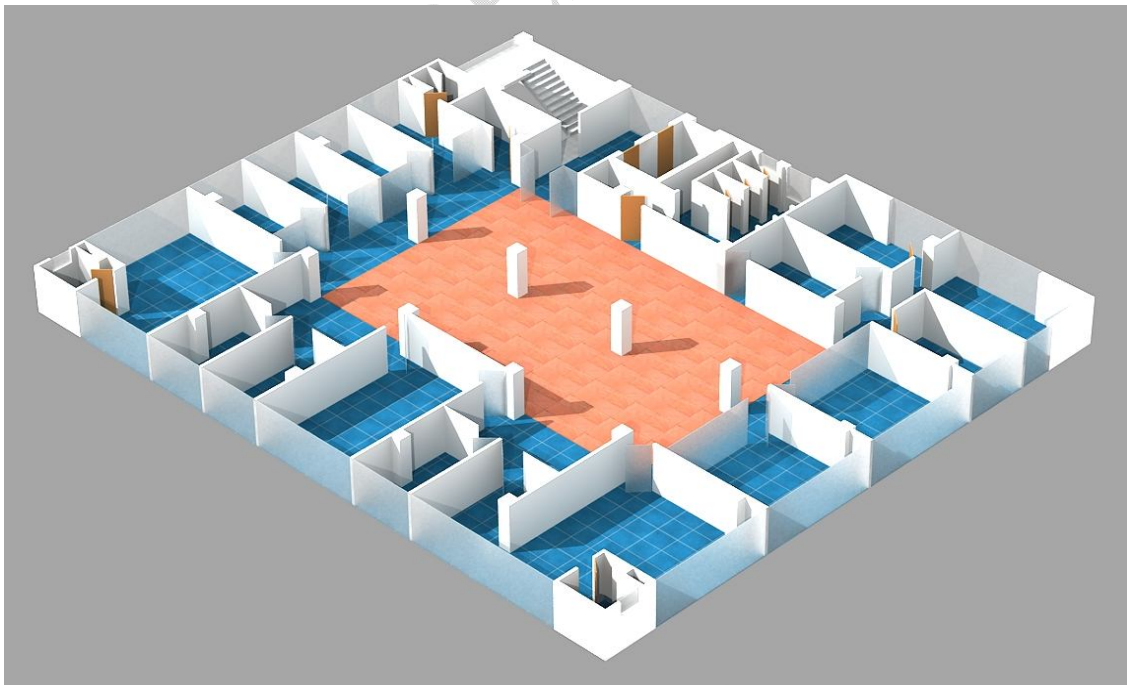

Figure 10. Axonometric view of 5th floor, Opsonin Building

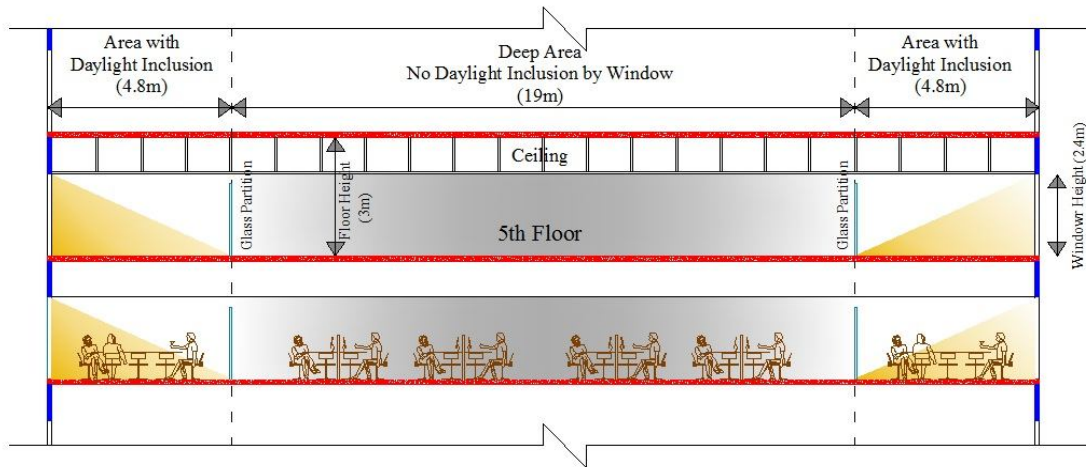

Figure 11. Typical section (Part) of nine storied Opsonin Building

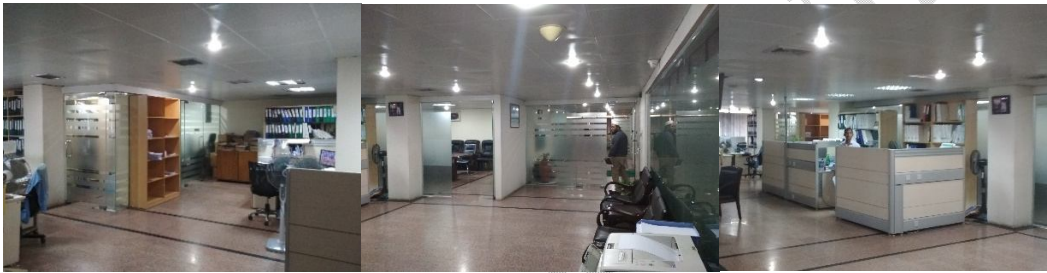

Figure 12. Interior view of 5th floor of Opsonin Building

5.0 SIMULATION MODEL PREPARATION

The parametric model 01 was created only with the open office area of selected office where direct sunlight can't enter and with vacant interior space without any partitions or furniture, to avoid the effects of such surfaces, which both block and reflect daylight (Fig. 13). The model 02 was created with the full area of surveyed office. (Fig. 14). The other parameters of the model of example space are mentioned below (Fig. 14-16). General Parameters of the selected office floor and simulation models (incorporated from values found in a physical survey) in Table 3.

Table 3. Parametric simulation specifications

Selected Office Floor	
5th Floor Dimensions:	25m X 28.65m
Total Floor Area:	692 sqm
Open Office Dimension	12m X 18m
Open Office Area:	216 sqm

Clear Height of Office Space	3m (without false ceilings) 2.4m (with metal false ceilings)
Work Plane Height:	0.75 m above floor level
Glass Specification:	Thickness: 10mm, Conductivity: 0.9 W/m-K, Visible Transmittance: 0.55, Solar Transmittance: 0.775. Density: 160 lb/ft ³
Simulation Model 01	
Simulation Area Dimension:	12m X 18m (open office area)
Simulation Area:	216 sqm
Simulation Model Height	3.65m
Transition Floor Height	3.65m
Work Plane Height:	0.75 m above floor level
Simulation Model 02	
Simulation Area Dimension:	25m X 28.65m (Total Floor)
Simulation Area:	692 sqm
Simulation Model Height	3.65m
Transition Floor Height	3.65m
Work Plane Height:	0.75 m above floor level

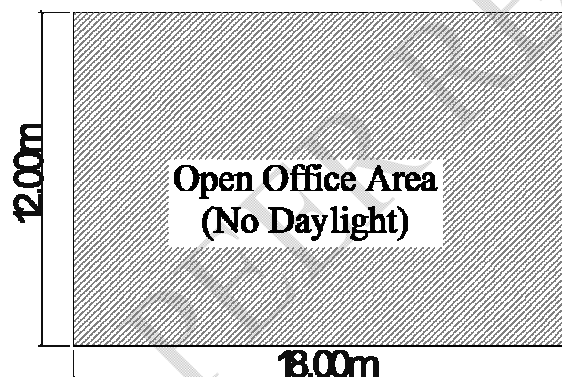

Figure 13. Model 01 Plan

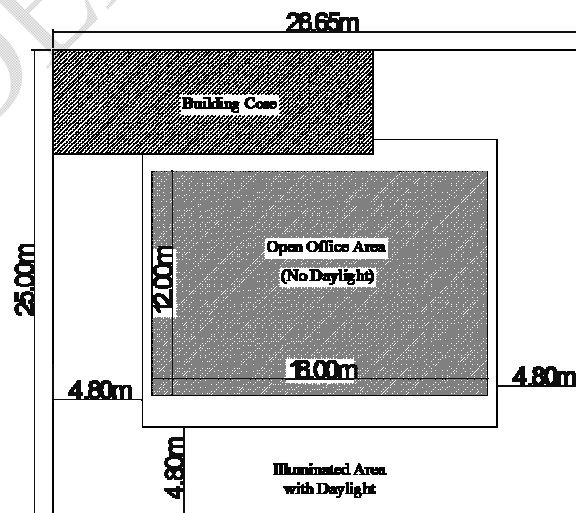

Figure 14. Model 02 Plan

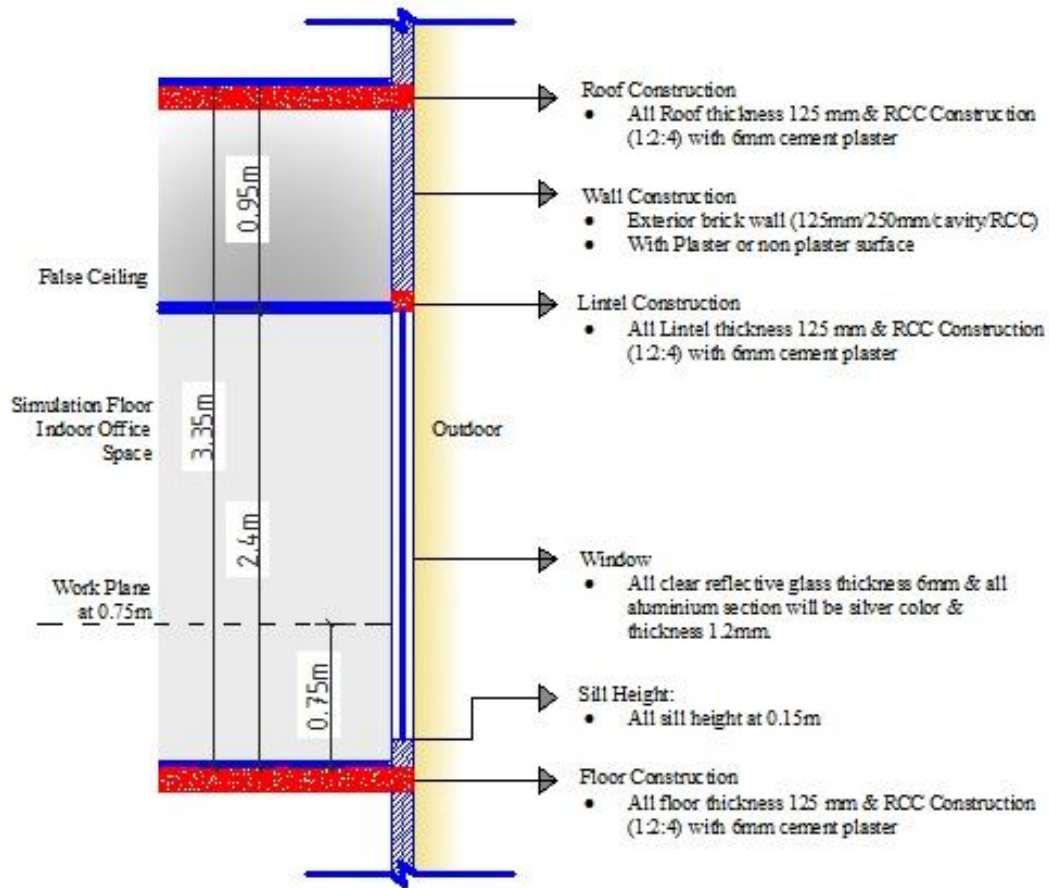

Figure 15.Detail section of office space for EnergyPlus simulation

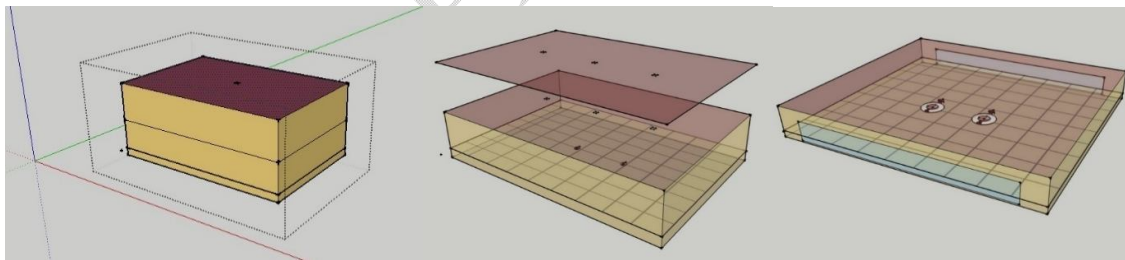

Figure 16. View of models used for the simulation. (Software: Open Studio/Sketch up)

Using an IDF editor or tools such as OpenStudio, specify the geometry, materials, schedules, and systems of the building to use the EnergyPlus simulation engine. The weather file in EPW format must be obtained for the project's location. The dhaka.epw weather data has been used for simulation in this instance. The simulation can then be run by loading the IDF and weather file, then executing it on the command line. Utilize output files such as HTML reports or CSV data to assess energy efficiency, lighting and thermal comfort. To optimize

performance, refine input parameters based on findings, and rerun simulations. Visualize and interpret results using OpenStudio or data analysis software (Brackney et al., 2018).

6.0 EXPERIMENTAL STUDY

Scale models are frequently used to evaluate daylighting performances of buildings (Nazari et al., 2024). To get accurate results, there are several rules to respect for building these scale models. Some of these rules are universal and others depend on the measurement and observation devices, the type of sky under which the study is carried out and the objectives of the study. This part discusses the experiments done by making scale models and observing the physical characteristics of daylight inclusion in the internal spaces of a building.

Experiment 01: Inclusion of Daylight by Side Wall and Roof

This model was studied to observe the daylight inclusion pattern by side window and roof. For this study, a conceptual model was used by maintaining the scale and proportion. Firstly, a single-story building model was made with hard white paper. The model's length and width were 2m and 1m and height was 1m. Model scale was 1:60 (Fig. 17).

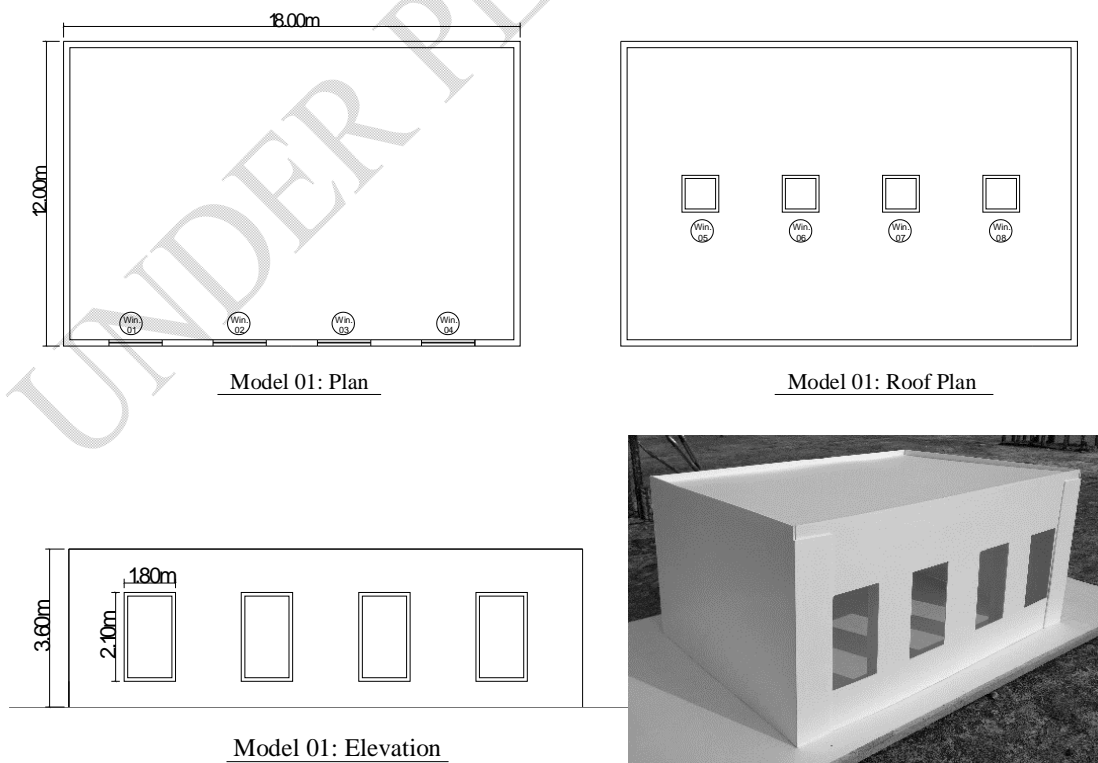



Figure17. Model for experiment 01

Then the model was placed outdoors where the sunlight comes uniformly. Then some experiments and observation were done by modifying the model wall and roof and observe and measure the daylight by Luxmeter (Dr.Meter) (Rahayu et al., 2021). Some images were taken by Thermal Imaging Camera to identify the presence of daylight (Yang et al., 2016).

In this experiment, the following steps have followed:

Step (a): At first there were no openings in the wall and roof of the model. So, there was no opportunity of inclusion of daylight in the interior space (Fig. 18).

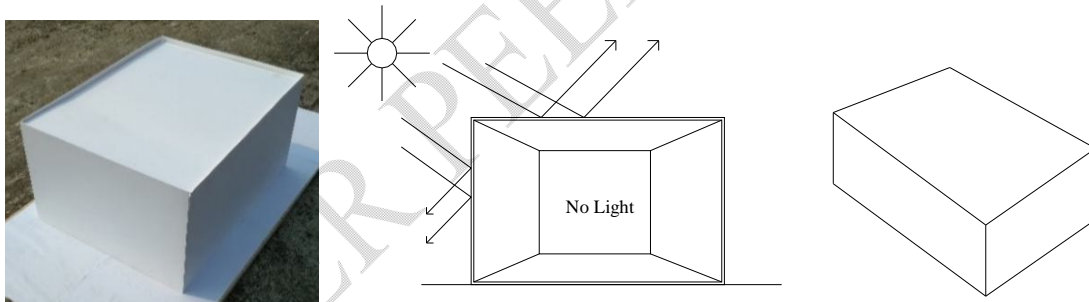

Figure18. Model and sectional perspective of step 1(a)

Step (b): There were four windows on one side of the model, but no opening on the roof. So direct daylight entered the model interior by side window (Fig. 19).



Figure 19. Model and sectional perspective of step 1(b)

Step (c): There were four skylights on the roof of the model, but no opening at side wall. So direct daylight entered the model interior by sky/roof window (Fig. 20).

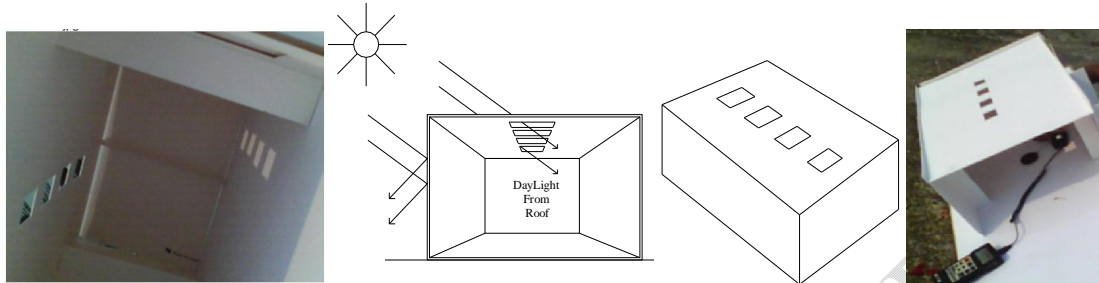

Figure20. Model and sectional perspective of step1(c)

Step (d): There were four windows on one side and four skylights on the roof of the model. So, a vast amount of direct daylight entered the model interior through the windows (Fig. 21).

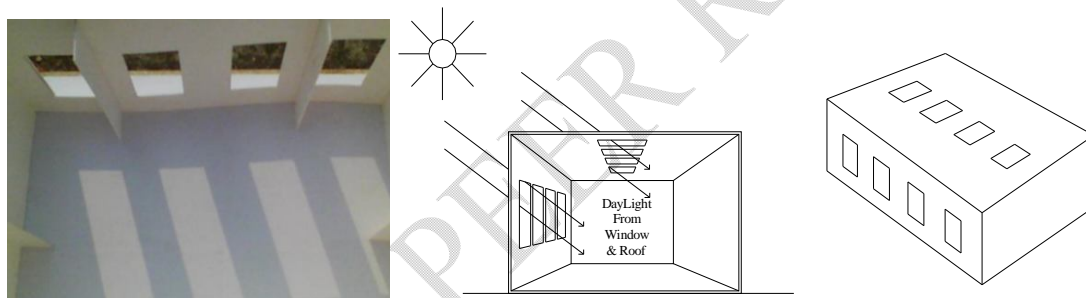

Figure21. Model and sectional perspective of step 1(d)

Experiment 02: Inclusion of Daylight by Light Pipe

This model was studied to observe the daylight inclusion pattern by light pipe. For the study, a multistoried building model has been made with hard white paper. The model was built with half of the open office area ($18\text{m} \times 12\text{m}$) which length was 9m and width was 6m. The height of the model per floor was 3.6m and total height was 10.8m. The model was built considering the surveyed floor, and it was a part of the real space, maintaining the scale of the model as comparable as real scale floor (Fig. 22-23). Model scale was 1:100. Reflective paper was used as the inner side material of light pipe and the cross-sectional area of the pipe was 6.25cm^2 ($2.5\text{cm} \times 2.5\text{cm}$).

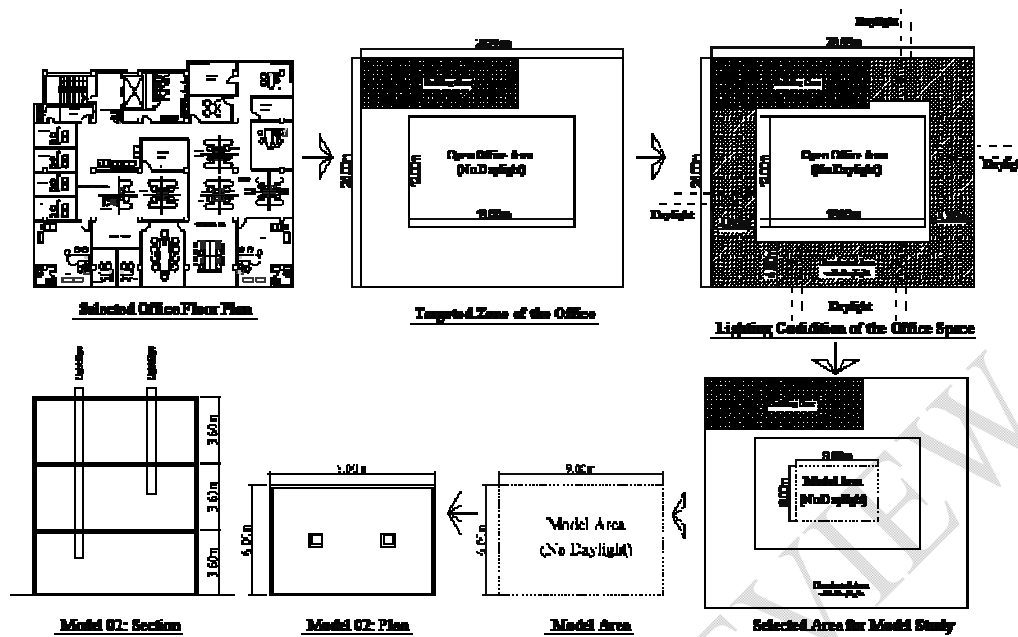

Figure 22. Selection of model area from selected office space



Figure 23. Model for experiment 02

Then some experiment/observation was done by modifying the length and direction of light pipe and observing the daylight inclusion pattern by the light pipes.

Step (a): Inclusion of Daylight by Straight Light Pipe

Firstly, two light pipes were built with paper which inner side was with reflected surface. The length of the pipes was different to observe the different situation. One pipe's length was roof

to ground floor, and another was roof to 1st floor. This experiment was done in an indoor environment by artificial light. When artificial light was on, a significant amount of light traveled through the light pipes, and it reached the respective floor by both pipes (Fig. 24).

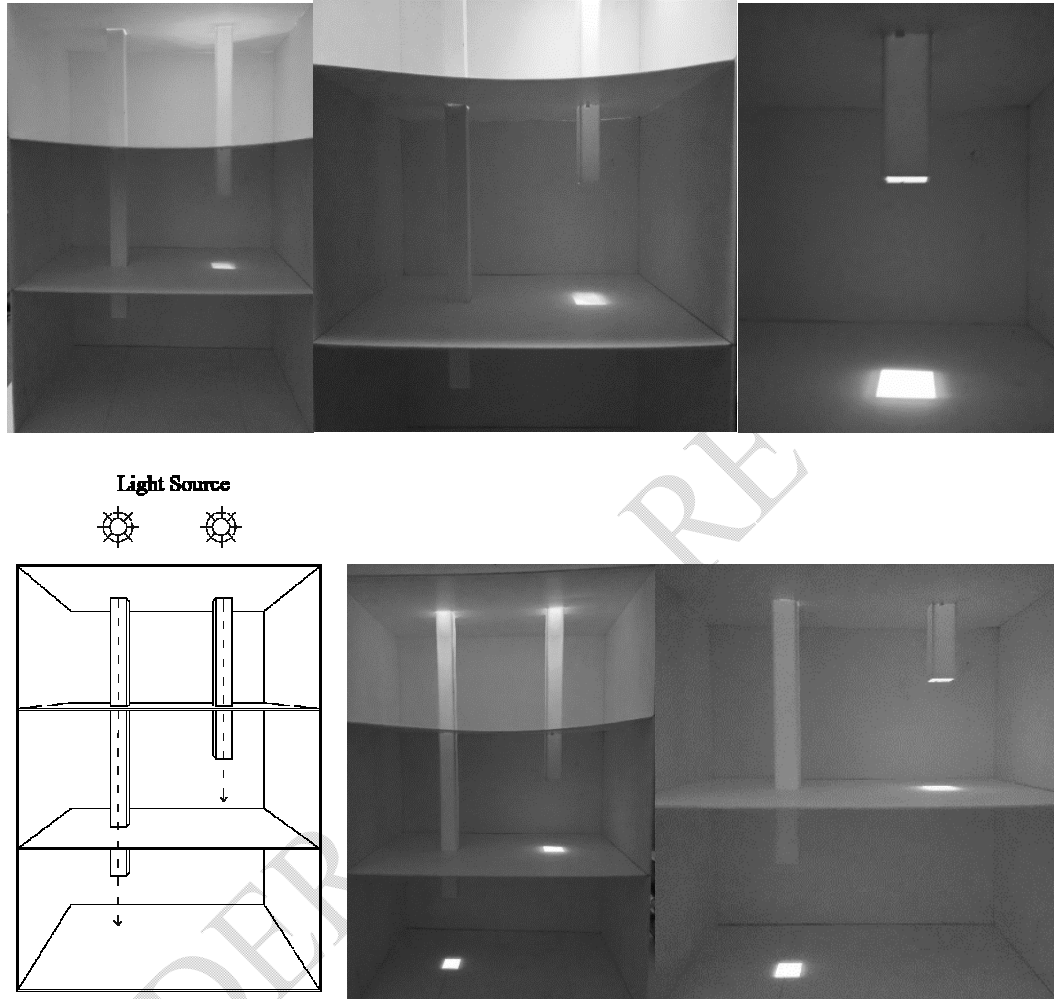

Figure 24. Model for step 2(a)

Step (b): Inclusion of Daylight by Bent Light Pipe

At this stage, the light pipes were modified and changed direction. One model light pipe was used, it started at roof, bent 90 degrees at the 1st floor level and bent 90 degrees again before entering at ground floor. This experiment was done in an indoor environment by artificial light. When artificial light was on, light traveled through the light pipe, and it reached to the ground floor by bent light pipe (Fig25).



Figure 25. Model for step 2(b)

7.0 ANALYTICAL INTERPRETATIONS FROM THE EXPERIMENTS

The experiments conducted with scaled models aimed to analyze the patterns of daylight penetration in office spaces through side and roof openings and light pipes, especially in scenarios where direct natural light could not access the interior through windows or roofs. These experimental setups were instrumental in understanding how daylight can be utilized effectively in various spatial configurations and building layouts. The findings from these experiments, summarized in Table 4, provide critical insights into daylight distribution and the potential application of light pipes as a solution for deeper interior spaces.

In both models there was an illuminance plane with 100 illuminance points at the work plane height. Daylight entered the interior space and was measured at the illuminance point. The simulation time was set for 1.00 am to 12.00 am, but as the office hour starts generally at 9.00am and finished at 6.00pm, only the numeric data of these 10 hours have been considered. Commonly it was found that maximum light entered at the middle of the day-that is 12.00pm. For this reason, it has been considered the illuminance of the 100 points of 12.00pm for analysis of every case. There were also two (2) daylight reference points named

“Daylighting Reference Point 1” and “Daylighting Reference Point 2”. Daylight was measured at both points also. Daylight penetration through side windows was observed to be effective for spaces located along the peripheral edges of office buildings. When unobstructed, the side windows allowed daylight to penetrate to a distance approximately equal to twice the height of the window (denoted as "2h"). This finding underscores the importance of maintaining clear, obstruction-free paths around side openings to maximize natural light usage. For spaces on the top floor, daylight entered efficiently through roof openings, directly illuminating areas beneath these openings. However, this method of daylight inclusion was ineffective for intermediate floors, as the presence of floors above blocked vertical access to daylight. This limitation highlighted the need for alternative methods to channel daylight into the building's core spaces. While considering only the illuminance level at the central part, it has generated a curve line which indicate that the highest light found at the center of the space and the lighting was very poor near the edge of the simulated area as installed light pipe with 0.50m diameter can't penetrate more light away from the center (Fig. 26).

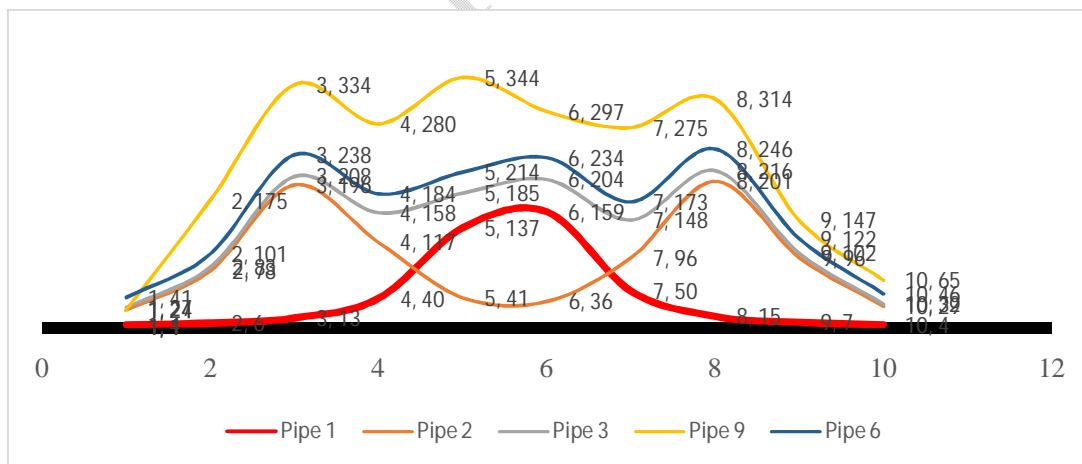

Figure 26. Daylighting distribution comparison at central part

The experimental studies show the lighting level at the central part of the illuminance plane for every variation for different length of light pipes with Model 01 (The deep part of the office floor).

From these data, it is observed that the difference of amount of daylight entered by light pipe of different length are very minimum. Daylight entered the office space at the same ratio by the time (hour) and reached at the maximum level at 12.00 PM. After 01.00 PM, it starts to decrease and reaches the minimum level at 06.00 PM (end of the office time). Maximum daylight entered by the light pipe of 3.65m length and minimum light found by the light pipe of 14.60 m length. The uniformity ratio below the light at work plane was found to be 0.36.

The brightest level of light 216 lux found at the center of the space and the light found at the periphery area was very low (less than 50 lux). The minimum light was only 6 lux. The average light was 57.8 lux, and the standard deviation was 55.2 lux were very close to each other. The median was 31.5 lux. The uniformity ratio below the light at work plane was 0.65 which met the standards (≥ 0.60).

Table 4. Observation from the Experiments

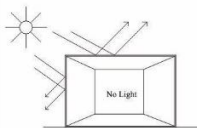
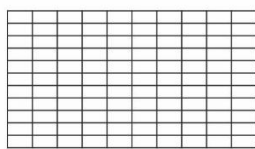
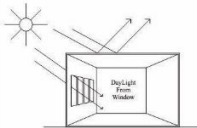
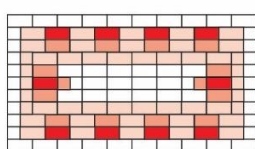
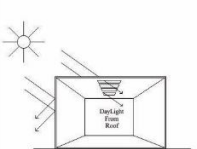
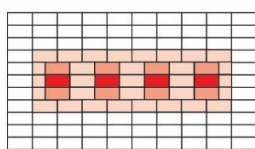
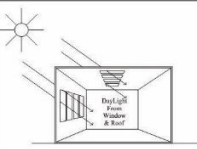
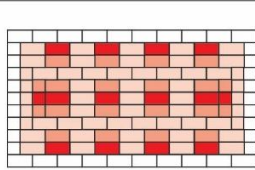
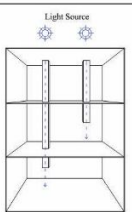
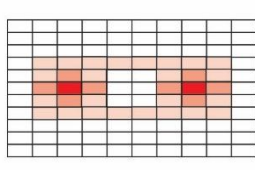
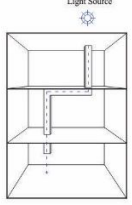
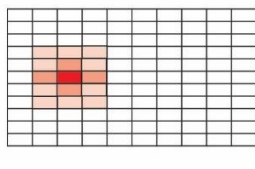
Experiment No./Steps	Category	Type/Name	Section	Location	Illumination
1(a)	Daylight	No Window/ Roof		Outdoor	
1(b)	Daylight	Window		Outdoor	
1(c)	Daylight	Roof		Outdoor	
1(d)	Daylight	Window & Roof		Outdoor	
2(a)	Artificial Light	Straight Light Pipe		Indoor	
2(b)	Artificial Light	Bending Light Pipe		Indoor	

The experiments also demonstrated that the central areas of intermediate floors, typically devoid of access to side windows or roof openings, could be effectively illuminated using light pipes. By installing light pipes, natural light could be directed to these otherwise dark zones, significantly enhancing their illumination without reliance on artificial lighting.

Further findings detailed the optimal use of light pipes. In scenarios where the target space had no obstructions above, straight light pipes provided the most efficient solution,

channeling daylight directly to the required areas. For situations where structural elements or other barriers obstructed the path of light, bent light pipes were found to be effective, allowing the light to navigate around obstacles and still reach the target spaces.

These observations collectively emphasize the importance of innovative daylighting strategies, such as light pipes, in addressing the challenges of natural light inclusion in office buildings. By leveraging these findings, architects and designers can develop more sustainable and health-conscious lighting solutions, ensuring enhanced comfort and productivity for office occupants.

8.0 RESEARCH LIMITATION

The study primarily focused on scaled models and simulation data, limiting its direct application to real-world scenarios. The experiments were conducted under controlled conditions, which may not fully replicate the complexities of actual office environments, such as dynamic weather patterns, diverse spatial configurations, or occupant behavior. Additionally, the research did not explore the long-term maintenance and cost implications of implementing light pipes in existing office buildings. Future research could investigate real-world installations of light pipes in various climatic contexts, integrating adaptive technologies like smart glazing and dynamic controls (Mukhtar et al., 2024). Exploring hybrid daylighting systems that combine light pipes with photovoltaic elements or automated shading devices could further enhance energy efficiency and occupant comfort (Wu et al., 2024; Mirparizi et al., 2023).

9.0 CONCLUSIONS

Field investigations were conducted to assess their effectiveness in office buildings. The main objective of this study was to assess the potential of light pipes. In addition, daylight inclusion patterns were observed in various office spaces with side openings as well as those without windows or roofs. It discussed field investigation to select simulation models and

experiments with scale models to observe the daylight inclusion pattern in different spaces of the office. This was done through side openings, roof and light pipes. The findings provide practical knowledge about office spaces and daylight inclusion patterns in those spaces. This knowledge helped to understand the findings of simulation models for light pipe studies. Core findings from this study are the followings:

- i. Side windows effectively illuminated spaces near peripheral edges, allowing light to reach approximately twice the window height (2h), provided no obstructions were present.
- ii. Maximum illuminance occurred at 12:00 PM, decreasing after 1:00 PM and reaching a minimum by 6:00 PM (end of office hours).
- iii. Central areas of spaces showed the highest illuminance levels, while peripheral areas experienced significantly lower light levels.
- iv. Straight light pipes (3.65m length) provided better illumination compared to longer pipes (14.60m), with minimal differences in daylight penetration across varying lengths.
- v. Light pipes with a 0.50m diameter provided maximum brightness at the center (216 lux), with very low levels (less than 50 lux) at the edges.
- vi. Average illuminance: 57.8 lux; standard deviation: 55.2 lux; median: 31.5 lux.
- vii. Uniformity ratio below the work plane was 0.65, meeting the standard (≥ 0.60).

Disclaimer (Artificial intelligence)

The author(s) hereby declares that AI technologies such as Large Language Models (ChatGPT, COPILOT, etc.) have been used during the writing or editing of this manuscript for some parts for referencing.

ACKNOWLEDGEMENT

The authors would like to thank Environmental Lab, Dept. of Architecture, Chittagong University of Engineering and Technology (CUET) for the support. The authors would also like to thank all the organizations and individuals who contributed to this study.

10.0 REFERENCES

Brackney, L., Parker, A., Macumber, D., & Benne, K. (2018). *Building energy modeling with OpenStudio*. New York: Springer International Publishing.

Canziani, R., Peron, F., & Rossi, G. (2004). Daylight and energy performances of a new type of light pipe. *Energy and buildings*, 36(11), 1163-1176.

Crawley, D. B., Lawrie, L. K., Winkelmann, F. C., Buhl, W. F., Huang, Y. J., Pedersen, C. O., & Glazer, J. (2001). EnergyPlus: creating a new generation building energy simulation program. *Energy and buildings*, 33(4), 319-331.

Islam, I., & Adnan, M. S. G. (2011). Commercial land use in Dhaka: an analysis of trends and patterns. *SU Ahmed, R. Hafiz & AKMG Rabbani (Eds.)*, 400, 277-296.

Joarder, M.A.R. (2007). "A Study of Daylight Inclusion in Luminous Environment of Offices in Dhaka City", Unpublished M.Arch Thesis. Department of Architecture, BUET, Dhaka.

Joarder, A.R., Ahmed, Z.N., Price, A. and Mourshed, M. (2009). *A simulation assessment of the height of light shelves to enhance daylighting quality in tropical office buildings under overcast sky conditions in Dhaka, Bangladesh*. IBPSA 2009 - Int. Build. Perform. Simul. Assoc. pp1706–1713.

Knoop, M., Stefani, O., Bueno, B., Matusiak, B., Hobday, R., Wirz-Justice, A., ... & Norton, B. (2020). Daylight: What makes the difference?. *Lighting Research & Technology*, 52(3), 423-442.

Mirparizi, M., Shakeriaski, F., Salehi, F., & Zhang, C. (2023). Available challenges and recent progress in carbon dioxide capture, and reusing methods toward renewable energy. *Sustainable Energy Technologies and Assessments*, 58, 103365.

Nazari, M., & Matusiak, B. (2024). Daylighting simulation and visualisation: Navigating challenges in accuracy and validation. *Energy and Buildings*, 114188.

Mukhtar, F. I., Salisu, A. S., & Salihu, M. M. (2024). Enhancing daylight in deep-plan offices for Nigeria's tropical climate: A light pipe approach. *Journal of Architecture, Planning and Construction Management (JAPCM)*, 14(1).

Paul, S. (2019). Investigation of dual ducting system for daylighting office buildings in Dhaka. M.Arch Thesis, Dept. of Architecture, BUET, Bangladesh.

Rahayu, D. S. R., Mak'ruf, M. R., & Syaifudin, S. (2021). Luxmeter Design with Proximity Sensor to Efficiently Test Light Intensity and Distance on Lamp Operation in Hospitals. *International Journal of Advanced Health Science and Technology*, 1(1), 20-25.

Sailor, D. J. (2008). A green roof model for building energy simulation programs. *Energy and buildings*, 40(8), 1466-1478.

Sawyer, A. O. (2022). Imagining daylight: Evaluating participants' perception of daylight in work environments. *Indoor and Built Environment*, 31(1), 96-108.

Wong, L. (2017). A review of daylighting design and implementation in buildings. *Renewable and Sustainable Energy Reviews*, 74, 959-968.

Wu, Y., Jin, M., Liu, M., & Li, S. (2024). Integrated Systems of Light Pipes in Buildings: A State-of-the-Art Review. *Buildings*, 14(2), 425.

Yang, J., Zuo, B., & Kim, S. H. (2016). Understanding the Factors Underlying Variation in Detection Errors of Video-and Thermal-Imaging Cameras. *Transportation research record*, 2557(1), 55-65.

UNDER PEER REVIEW